



PACIFIC WATER TECHNOLOGY

# Runxin 53520 Filter Valve

## Instruction Manual





**Table of Contents**

Installation Summary	Page 3
General Specifications	Page 4
Installation	Page 5
Service cycles	Page 6
Parameter Settings	Page 7
Valve Breakdown	Page 8
Circuit Board Functions	Page 9
Valve Settings	Page 10-11
Flow Rate Curve	Page 12
Trouble Shooting	Page 13-14



**Installation Summary**

Installation Location: \_\_\_\_\_ Installation Date: \_\_\_\_\_

Installed by: \_\_\_\_\_ Phone: \_\_\_\_\_

Application Type: \_\_\_\_\_

**Water Source:** \_\_\_\_\_

**Water Test Results**

Hardness: \_\_\_\_\_ Iron: \_\_\_\_\_ pH: \_\_\_\_\_

Other: \_\_\_\_\_

**Misc:**

Tank Size:

Diameter \_\_\_\_\_ Height: \_\_\_\_\_

Resin or Media Type: \_\_\_\_\_

Resin or Media Volume: \_\_\_\_\_ Brine tank Size: \_\_\_\_\_

Capacity: \_\_\_\_\_

Service Flow Rate:

Min: \_\_\_\_\_ Max: \_\_\_\_\_ Backwash: \_\_\_\_\_

Inlet Pressure: \_\_\_\_\_ KPa

**Control Valve Configuration**

Valve Type: \_\_\_\_\_ Valve Part No. \_\_\_\_\_

Serial Number: \_\_\_\_\_

Regenerant Refill Control: \_\_\_\_\_ Gpm/lpm      Injector Type: \_\_\_\_\_ Gpm/lpm

Drain line flow control: \_\_\_\_\_ Gpm/lpm

Parameter	Unit	Factory Default	Actual Value
Service Days(Time clock type, by days)	D.	03	
Service Hours(Time clock type, by hours)	H.	20	
Rinsing Time	/	02:00	
Rinsing Frequency	/	F-00	
Backwash Time	Min.	10	
Fast Rinse Time	Min.	10	
Output Mode b-01(02)	/	b-01	



## General Specifications

### Operating

Minimum/Maximum operating pressures: 20psi (138kPa) – 87psi (600kPa)

Minimum/Maximum Operating Temperature: 5°C -50°C

Power Supply: 240V/50Hz DC24V 1.5A

### Connections

Inlet: 2" Male BSP

Outlet: 2" Male BSP

Waste: 2" Male BSP

Riser Pipe: 2" D-GB (63mm OD)

Tank Thread: 4"-8UN

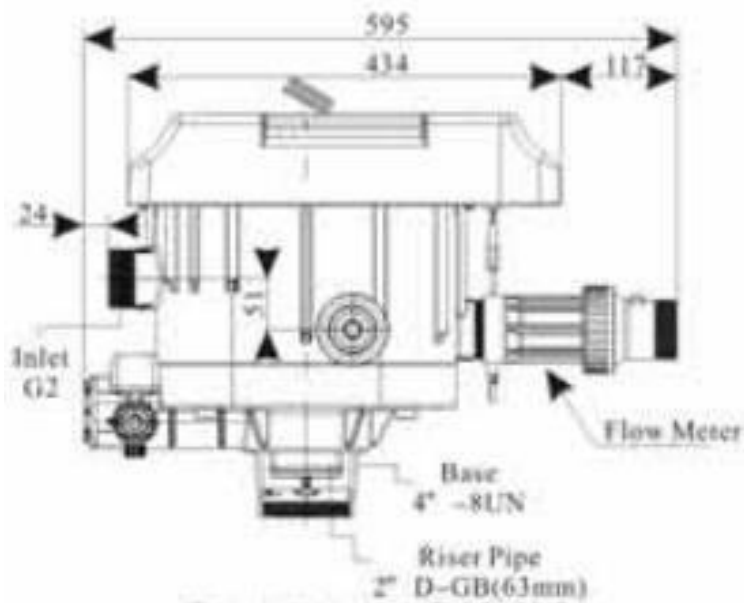



## **Installation**

Before Installation, read instructions thoroughly. The installation of the system should be completed by a professional.

### **36x72" GS1000 High Absorption micro pollutants, Carbon Media Loading:**

160kg 3-6mm #5 Underbed Gravel (Load in tank first)

80kg 8/16 #6 Underbed Gravel (Load in tank second)

210kg GS1000 (8x30) Carbon (Load in tank last)

*342LPM Backwash Flow control supplied with valve*

Use filling funnel provided:



**Do not use Vaseline, oils, or Spray silicone on valve O-rings. 100% Silicone Lubricant must be used for the O-rings**

Locate the system as close as possible to the nearest drain.

The cylinder should be situated on a firm, level surface.

The system should be kept away from boilers, heater and installed inside.

Allow adequate space for pipework and removal of the valve when it is due for servicing equipment.

All pipework should be done in accordance with local plumbing regulation and codes.

Do not use the valve as a support mechanism for pipework use correct supports.

It is recommended to install bypass for the system, to allow for works to be performed on the valve or cylinder without interruption to production. **(Figure 1)**

If the installer is soldering pipework, it is important no pipework is connected to the valve as the heat will damage the system.

When using Teflon tape be careful not to cross thread the fittings.

Allow an air gap when plumbing the waste line to drain.

Riser pipe should be cut off flush with the top of the cylinder and deburred.

Centre the riser in the cylinder and plug to not allow any media to enter riser when filling the cylinder, fill the media as per suppliers' recommendations.

Remove plug and fill system slowly with water

Once cylinder is 90% full of water install the valve, making sure not to cross thread the valve.

Connect inlet, outlet and drain line to the valve.

Turn on power to the valve and check system settings are correct

Put system into back wash and then slowly open the inlet valve to allow for air to be removed from the system.

Once air has been removed and a constant flow of water is running down the backwash line, open the inlet fully until all fines from the media has flushed out of the system. (This may require 2-3 backwashes)

After backwash make sure to put the valve into flush to settle the media bed.

After backwash is complete check for any leaks within the system and pipework.

Fig.1

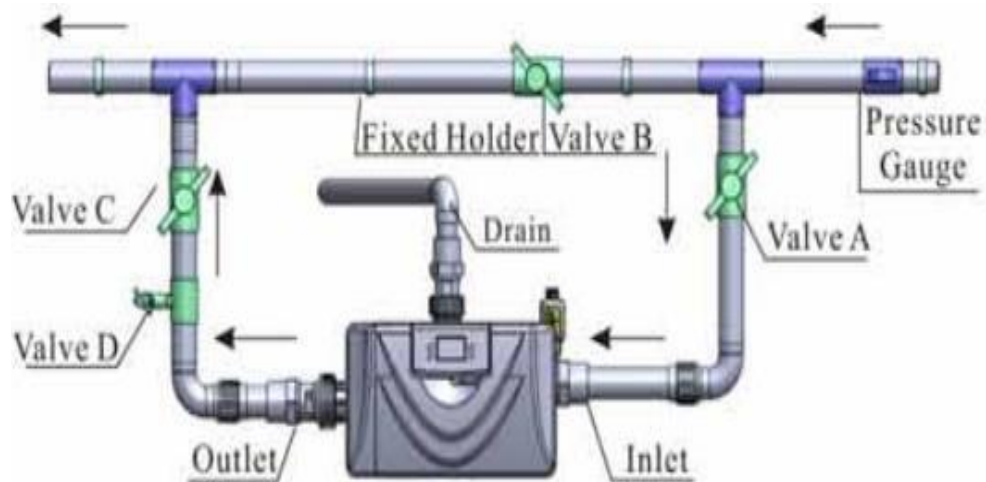



## **System Status**



Service Status: Unfiltered water is directed through the media bed and up through the distributor and riser pipe.

Backwash Status: The flow of water is redirected down the riser and up through the media bed, lifting the media and removing the sediment down the waste line.

Fast Rinse Status: The Flow of water is directed through the media bed and up through the distributor and riser pipe and sent to drain. This is to allow the media bed to resettle and remove any sediment that may be left in the pipework from the backwash.

## Display Icons Runxin Controller



PACIFIC WATER TECHNOLOGY

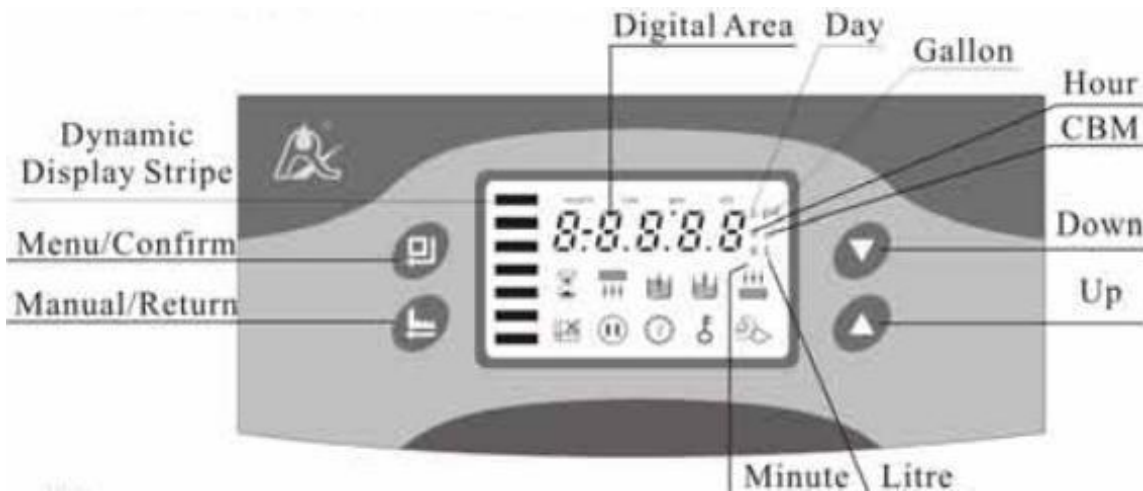

## Parameter Specifications

Function	Indicator	Factory Default	Parameter Set Range	Instruction
Time of Day		Random	00: 00~23:59	Set the time of day when use. “: ” flash
Service Days		1-03D.	0~99Days	Only for Time Clock Type, by days
Service Hours		1-20H.	0~99 Hours	Only for Time Clock Type, by hours
Rinsing Time	02:00	02:00	00: 00 ~ 23:59	Rinsing time; “: ” light on
Rising Frequency	F-00	00	0 ~ 20	Rising frequency. For example,F-01: indicate service 1 time, backwash and fast rinse 2 time;
Backwash Time		10Min.	0 ~ 99:59	Backwash time(Minute), correct to second;
Fast Rinse Time		10Min.	0 ~ 99:59	Fast Rinse Time(Minute), correct to second;
Output Control Mode	b-01	01	01 or 02	Mode 01: Signal turn on start of rinsing and shut off end of rinsing. (Refer to the figure on P5) Mode 02: Signal available only intervals of rinsing cycles and in service. (Refer to the figure on P5)



# Valve Breakdown



PACIFIC WATER TECHNOLOGY

Item No.	Description	Part No.	Quantity	Item No.	Description	Part No.	Quantity
1	Screw, Cross St3.9X19	8909003	13	31	Cable Clip	8126001	1
2	Connector	8458018	1	32	Screw, Cross ST2.2X6.5	8909004	8
3	O-ring 104.6X5.7	8378146	1	33	Display Board	6381007	1
4	O-ring 63X3.55	8378163	1	34	Board Front Cover	8300013	1
5	Valve Body	5022085	1	35	Sticker	8865011	1
6	Hexagonal Bolt Set M5x20	5851006	4	36	Bushings	8126006	1
7	Injector Cover	8315007	1	37	Three-core Spring	5517001	1
8	O-ring 52X3	8378096	1	38	Control Board	6382049	1
9	Injector	5468020	1	39	Wire for Locating Board	5511016	1
10	Seal Ring	8371019	1	40	Front Cover	8300032	1
11	Electronic Ball Valve	2976064	1	41	Toggle	8126004	2
12	Seal Ring	8371008	1	42	Wire for Power	5513001	1
13	Flow Control	8468049	1	43	Probe Wire	6386010	1
14	Animated Connector	8947005	1	44	Gear	5241018	1
15	Hexagonal Bolt ST3.9X16	8909016	4	45	Pin 2.5X12	8993004	2
16	Junction Plate	8152019	1	46	Shaft	8258027	1
17	Seal Ring	8370078	1	47	Moving Disk	8459072	1
18	Fixed Disk	8469072	1	48	Fixed Disk	8469074	1
19	Moving Disk	8459071	1	49	Seal Ring	8370079	1
20	Shaft	8258005	1	50	Hexagonal Nut	8940002	4
21	Anti-friction Washer	8216006	2	51	Locking Ring	8994009	2
22	O-ring 59.92X3.53	8378110	4	52	Small Gear	8241008	2
23	O-ring 123.19X5.33	8378161	4	53	Pin 2.5X12	8971001	2
24	Pressure Nut	8092035	2	54	Motor	6158039	1
25	Locating Board	6380027	1	55	Motor	6158038	1
26	Screw, Cross ST2.9X9.5	8909008	12	56	Flow Meter	5447003	1
27	Gear	5241017	1	57	Screw, Cross Set M4x12	8902005	4
28	Screw, Cross ST4.8X19	8909018	2	58	Screw, Cross M4X25	8902008	8
29	Dust Cover	8005037	1	59	Display Shelf	8040003	1
30	Board Back Cover	8315008	1				

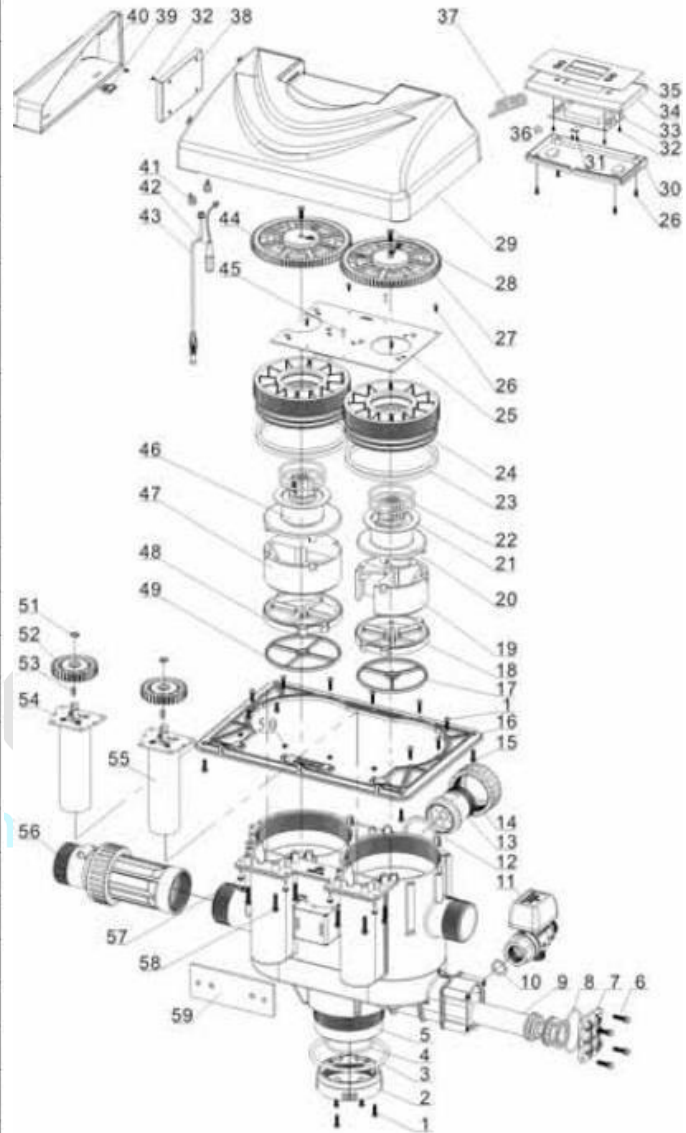



### Signal Output

There is a signal output connector on the circuit board. It is for controlling external wiring (Refer to Figure 2 and Figure 3).

There are two kinds of output modes.

b-01: Sends signal start of backwash and stops sending signal at end of rinse cycle

b-02: Sends signal in between cycles

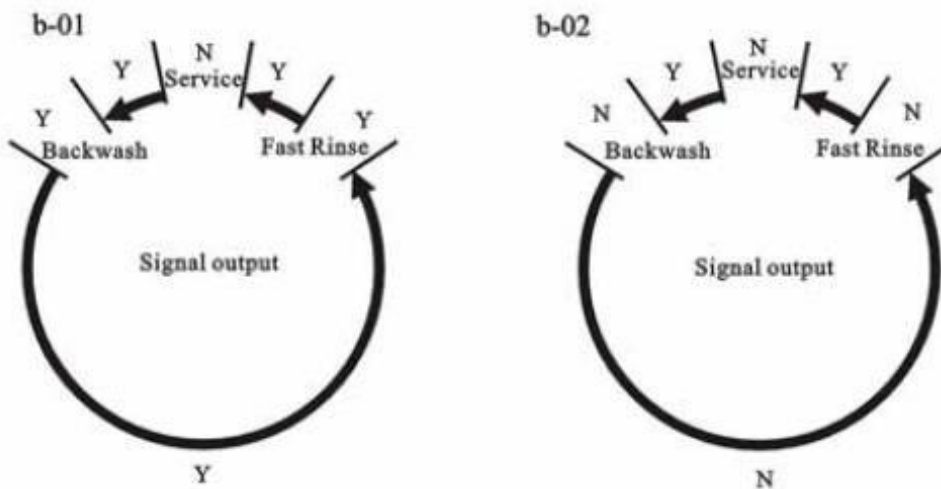

### Interlock Function

The circuit board has an interlock function to send a signal between Runxin valves in a parallel set up. When one of the units has started a backwash, the signal will be sent to the other valve and lock it out from performing a backwash until the first valve has completed its cycles.

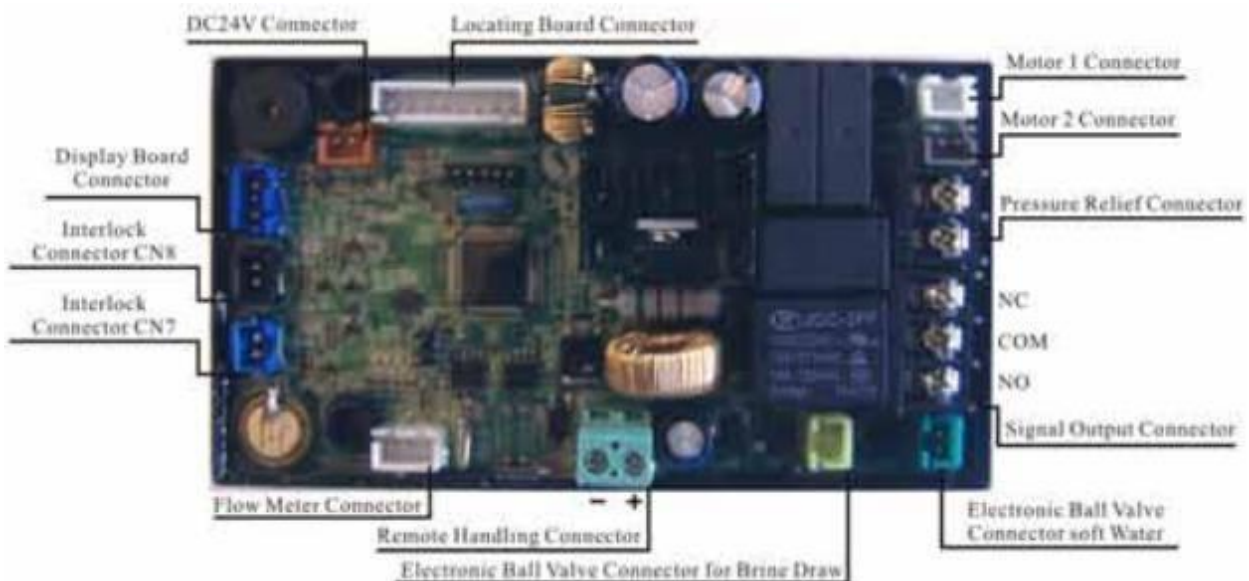



## **Initial Power Up**

The valve may need to return to the service position.

The ceramic disc will return to service position and -00- will be displayed when in motion.

This should be completed within 1 minute (if this takes longer than 2minutes please contact Dealer)

## **To initiate a Manual Regeneration**

- Unlock Valve – Press Up & Down arrow together for 5 secs until you hear a beep.
- Press the Manual/Return button
- F-00 will be displayed and Backwash will start
- To skip a cycle, press the Manual/Return button again

## **To Set Clock**

- Unlock Valve – Press Up & Down arrow together for 5 secs until you hear a beep.
- Press the Menu Button.
- The time will be displayed with the enquiry/setting symbol and clock symbol illuminated
- Press Menu button again.
- The hour time will flash.
- Change the Hour time to correct time by pressing the up or Down button & press Menu to save.
- The minutes will then flash.
- Change the minutes time with the up or down arrow and press menu to confirm changes.

## **Set Regeneration Time**

- From the Set Clock setting press the down arrow.
- Press Menu – The hour will then flash change the Hour time to desired time by pressing the up or Down button & press Menu to save.
- The minutes will then flash.
- Change the minutes time with the up or down arrow and press menu to confirm changes.

## **Leave the next setting at F-00**



## How to change Regeneration Days Override

- From the F-00 setting press the down arrow
- The hourglass symbol and enquiry/setting symbol will be illuminated,
- Press the Menu Button
- The Digits will then flash change the number to desired number of days by pressing the up or Down button & press Menu to save.

## To Change Regeneration Cycle Minutes

### Backwash      2-##

- From the days override setting press the down arrow.
- The backwash symbol and enquiry/setting symbol will be illuminated, press menu, the time will flash, press the up and down arrows to change to desired minutes
- Press menu to confirm

### Fast Rinse      3-##

- Once backwash is set, Press down
- The Fast Rinse symbol and enquiry/setting symbol will be illuminated, press menu, the time will flash, press the up and down arrows to change to desired minutes
- Press menu to confirm

Function	Indicator	Factory Default	Parameter Set Range	Instruction
Time of Day		Random	00: 00~23:59	Set the time of day when use. “: ” flash
Service Days		1-03D.	0~99Days	Only for Time Clock Type, by days
Service Hours		1-20H.	0~99 Hours	Only for Time Clock Type, by hours
Rinsing Time	02:00	02:00	00: 00 ~ 23:59	Rinsing time; “: ” light on
Rising Frequence	F-00	00	0 ~ 20	Rising frequence. For example,F-01: indicate service 1 time, backwash and fast rinse 2 time;
Backwash Time		10Min.	0 ~ 99:59	Backwash time(Minute), correct to second;
Fast Rinse Time		10Min.	0 ~ 99:59	Fast Rinse Time(Minute), correct to second;
Output Control Mode	b-01	01	01 or 02	Mode 01: Signal turn on start of rinsing and shut off end of rinsing. (Refer to the figure on P5) Mode 02: Signal available only intervals of rinsing cycles and in service. (Refer to the figure on P5)



# Flow rate Curve

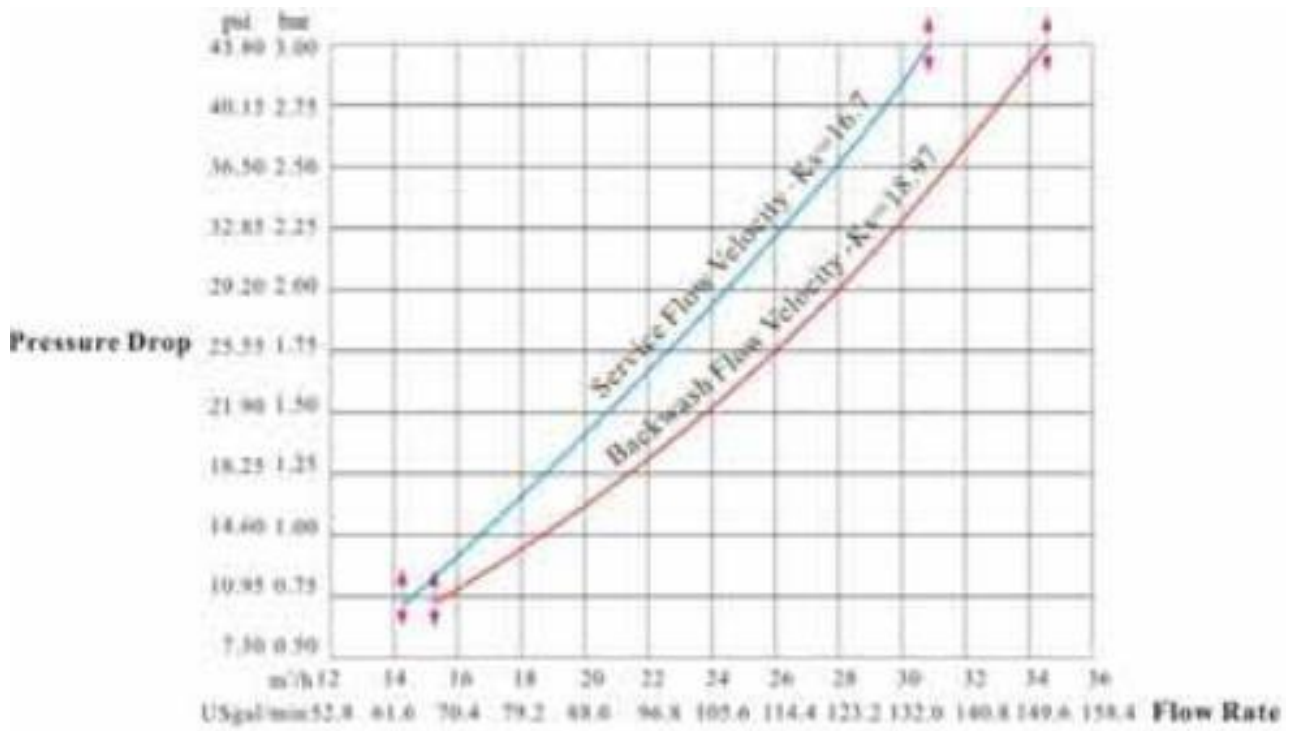



## Troubleshooting

<b>Problem</b>	<b>Possible Cause</b>	<b>Solution</b>
Filter Fails to Backwash	<ul style="list-style-type: none"> <li>a. Power to controller has been interrupted</li> <li>b. Backwash cycle times set incorrectly</li> <li>c. Controller Damaged</li> </ul>	<ul style="list-style-type: none"> <li>a. Check power connection is ok</li> <li>b. Reset the backwash cycle times</li> <li>c. Check or replace controller</li> </ul>
Filter passing raw water	<ul style="list-style-type: none"> <li>a. Bypass valve is open</li> <li>b. Damaged riser pipe</li> <li>c. Internal Valve Leak</li> </ul>	<ul style="list-style-type: none"> <li>a. Close Bypass Valve</li> <li>b. Check the riser pipe is not cracked and O-ring is ok</li> <li>c. Check or change valve body</li> </ul>
Water pressure loss	<ul style="list-style-type: none"> <li>a. Filter requires a backwash</li> <li>b. Check no blockage in Pipework</li> </ul>	<ul style="list-style-type: none"> <li>a. Backwash filter</li> <li>b. Unblock pipework</li> </ul>
Loss of media material through drain line	<ul style="list-style-type: none"> <li>a. Air in the system</li> <li>b. Backwash flow control to high</li> <li>c. Top screen broken</li> </ul>	<ul style="list-style-type: none"> <li>a. Bleed air from the system. Check for leaks</li> <li>b. Reduce Backwash flow to suitable size</li> <li>c. Check and replace top screen</li> </ul>
Control valve cycle continuously	<ul style="list-style-type: none"> <li>a. Wrong size transformer</li> <li>b. Foreign material stuck in drive gear</li> <li>c. Faulty valve</li> </ul>	<ul style="list-style-type: none"> <li>a. Use correct Transformer</li> <li>b. Remove Foreign material from drive gear</li> <li>c. Replace valve</li> </ul>
Water flowing through drain line continually	<ul style="list-style-type: none"> <li>a. Power outage during backwash or fast rinse</li> <li>b. Internal Valve leak</li> </ul>	<ul style="list-style-type: none"> <li>a. Turn on Power, cycle through to service</li> <li>b. Check or replace valve body</li> </ul>
All indicators display on the controller	<ul style="list-style-type: none"> <li>a. Wiring between the display board and control board failure</li> <li>b. Control board is faulty</li> </ul>	<ul style="list-style-type: none"> <li>a. Check a replace cable</li> <li>b. Replace control board</li> <li>c. Check or replace transformer</li> </ul>



	<ul style="list-style-type: none"> <li>c. Transformer damaged</li> <li>d. Incorrect voltage</li> </ul>	<ul style="list-style-type: none"> <li>d. Replace transformer with correct size</li> </ul>
No display on controller	<ul style="list-style-type: none"> <li>a. Wiring between the display board and control board failure</li> <li>b. Control board is faulty</li> <li>c. Display board is faulty</li> <li>d. Transformer damaged</li> <li>e. Power outage</li> </ul>	<ul style="list-style-type: none"> <li>a. Check a replace cable</li> <li>b. Replace control board</li> <li>c. Replace display board</li> <li>d. Check or replace transformer</li> <li>e. Check power supply</li> </ul>
E1 Flash	<ul style="list-style-type: none"> <li>a. Wiring between the locating board and display board failure</li> <li>b. Locating board damaged</li> <li>c. Mechanical driver fails</li> <li>d. Faulty control board</li> <li>e. Wiring between the control board and motor fault</li> <li>f. Motor damaged</li> </ul>	<ul style="list-style-type: none"> <li>a. Replace the wiring between display board and locating board</li> <li>b. Replace locating board</li> <li>c. Check and repair mechanical part</li> <li>d. Replace control board</li> <li>e. Replace wiring between control board and motor</li> <li>f. Replace motor</li> </ul>
E2 Flash	<ul style="list-style-type: none"> <li>a. Component on locating board damage</li> <li>b. Wiring of locating board fails to work</li> <li>c. Control board is faulty</li> </ul>	<ul style="list-style-type: none"> <li>a. Replace locating board</li> <li>b. Replace locating board wiring</li> <li>c. Replace Control board</li> </ul>
E3 or E4 Flash	<ul style="list-style-type: none"> <li>a. Control board is faulty</li> </ul>	<ul style="list-style-type: none"> <li>a. Replace Control Board</li> </ul>

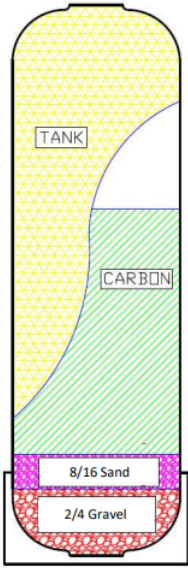

COAL CARBON FILTER MEDIA LOADING															
Filter Tank Size	2/4 Gravel			8/16 Sand			Coal Carbon				Recommended Flow Rates LPM				
	Kgs	Bag Qty	Order Qty	Kgs	Bag Qty	Order Qty	Kgs	Vol. L	Bag Qty	Order Qty	Service MIN 7 m/hr	Service MAX 12.5 m/hr	Service PEAK 25.5 m/hr	B/Wash MIN 25.5 m/hr	B/Wash MAX 30 m/hr
9x48	-	-	-	7.50	0.40	1.00	14.25	28.50	1.10	2.00	4.80	8.50	17.40	17.40	20.50
10x54	-	-	-	10.00	0.50	1.00	17.75	35.50	1.40	2.00	6.00	10.60	21.70	21.70	25.50
12x52	-	-	-	15.00	0.80	1.00	28.25	56.50	2.30	3.00	8.50	15.20	31.00	31.00	36.50
13x54	-	-	-	20.00	1.00	1.00	31.75	63.50	2.50	3.00	10.00	17.90	36.60	36.60	43.00
14x65	-	-	-	25.00	1.30	2.00	42.50	85.00	3.40	4.00	11.60	20.60	42.10	42.10	49.50
16x65	20.00	1.00	1.00	10.00	0.50	1.00	49.50	99.00	4.00	4.00	15.20	27.10	55.30	55.30	65.00
18x65	25.00	1.30	2.00	18.00	0.90	1.00	63.75	127.50	5.10	6.00	18.70	33.30	68.00	68.00	80.00
21x62	40.00	2.00	2.00	25.00	1.30	2.00	85.00	170.00	6.80	7.00	25.70	45.80	93.50	93.50	110.00
24x72	60.00	3.00	3.00	30.00	1.50	2.00	113.25	226.50	9.10	10.00	33.80	60.40	123.30	123.30	145.00
30x72	120.00	6.00	6.00	60.00	3.00	3.00	184.00	368.00	14.70	15.00	53.70	95.80	195.50	195.50	230.00
36x72	160.00	8.00	8.00	80.00	4.00	4.00	261.75	523.50	20.90	21.00	77.00	137.50	280.50	280.50	330.00
42x72	300.00	15.00	15.00	100.00	5.00	5.00	382.00	764.00	30.60	31.00	103.80	185.40	378.30	378.30	445.00
48x72	475.00	23.80	24.00	120.00	6.00	6.00	523.50	1047.00	41.90	42.00	136.50	243.80	497.30	497.30	585.00
63x86	975.00	48.80	49.00	250.00	12.50	13.00	775.00	1550.00	62.00	62.00	234.60	419.00	854.70	854.70	1005.50

Service & Backwash Flow Rates shown are based on general recommended rates for normal conditions as per Carbon Activated's brochure.

Coal Carbon Bag QTY: Based on 12.5KG Bags

Underbed 2/4 Gravel & 8/16 Sand Bag QTY: Based on 20KG Bags

Important Note: A number of calculations have been rounded off.